

Part number

CXF 6/6



Brief description:

female insert, 6 poles + PE, crimp connections, 100A 690V, (6 poles (16A max - 400V)), 8kV, 3, for female contacts 100A and 16A, size "104.27", CLASS insert series

Product description		Approvals / Standards	
Model	female insert	Reference standard	EN 61984 (2001-11)
Version	crimp connections	Quality mark	EAC
Series	CX	Conformity	CQC, CE
Product type	for female contacts 100A and 16A	General ordering information	
Family	CLASS inserts	EAN13 code	8015747192170
Size	size "104.27"	Tariff number	85369095
N. of poles	6 poles +	Country of origin	Made in EU (IT)
Auxiliary poles	6 poles (16A max - 400V)	ETIM classification	EC000438
Technical data		Packaging Information	
Current	100 A (A.C. and D.C.)	Packaging length	130,00 mm
Voltage	690 V	Packaging height	145,00 mm
Rated impulse withstand voltage	8kV	Packaging width	300,00 mm
Pollution degree	3	Packaging weight	1,32 kg
Operating temperature range (min, max)	-40°C ... +125°C	Packaging volume	5,66 dm ³
Mating cycles	≥ 500	Packaging description	Carton box
IP degree of protection	IP20 without enclosure; IP65/IP66/IP67/IP68 with enclosure	Packaging quantity	10 Pcs
PE connection type	Screw	Packaging EAN code	8015747192187
PE terminal stripping length	100A: 15mm; 16A: 7,5mm	Sub-packaging weight	0,13 kg
Tightening torque for PE connection	M4: 1,2 Nm, 10,6 lb.in (Ph2 or 1,0x5,5mm)	Sub-packaging description	Plastic bag
Sub-packaging quantity		Sub-packaging quantity	1 Pcs
Sub-packaging EAN barcode		Sub-packaging EAN barcode	8015747192194
Further technical details			
Characteristics according to EN 61984	100A 690V 8kV 3 (aux: 16A 400V 6kV 3)		
Insulation resistance	≥ 10 GΩ		
Contact resistance	≤ 0,3 mΩ (100A); ≤ 1 mΩ (16A)		
Rated voltage according to UL/CSA	600V		
UL 94 flammability rating	V-0		
Main contacts stripping length	100A: 15mm; 16A: 7,5mm		
Tightening torque for fixing screws	M3: 0.5 Nm; 4.4 lb.in (Ph1 or 0.8x4 mm)		
Weight	116,50 g		

Part number

CXF 6/6



Catalogue drawings

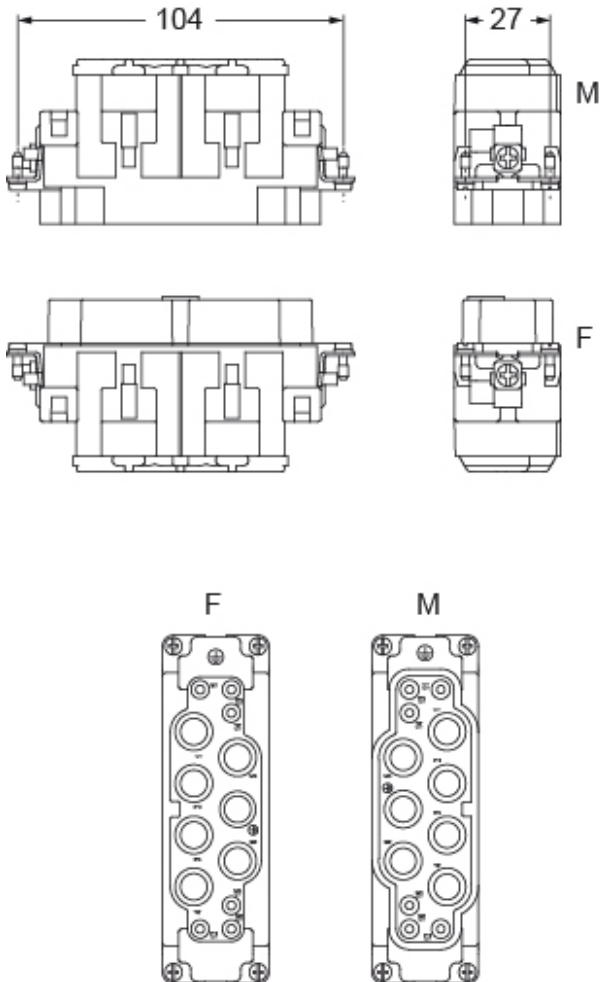

Notes

CXF/M 6/6

- characteristics according to EN 61984:
100A 690V 8kV 3
16A 400V 6kV 3
- insulation resistance: > 10 GOhm
- ambient temperature limit: -40 °C ... +125 °C
- made of self-extinguishing thermoplastic resin UL 94 V0
- mechanical life: > 500 cycles
- contact resistance: < 0,3 mOhm (100A) - < 1 mOhm (16A)
- for contact crimping, see the crimp tool section (100A contacts CG series, and 16A contacts CC series)
- enclosures: size "104.27":
C-TYPE IP65/IP66
C7 IP67 stainless steel lever
V-TYPE IP65/IP66 stainless steel lever
T-TYPE IP65 insulating
JEI zinc-plated steel lever
BIG hoods

W-Type for aggressive environment

EMC

central lever

IP68

- panel supports:COB

- enclosures: bulkhead mounting housings, high construction housings or high construction hoods